

ACUC DIVE TABLES

Presented by Rick Jakes

ACUC 1581CA

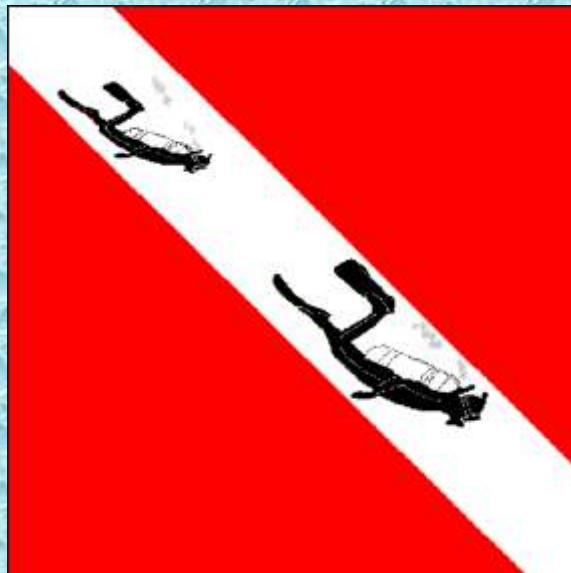

**KELSEY SCUBA
CLUB**

ACUC Dive Tables

1. What Are Dive Tables?

2. Why Do We Use Dive Tables?

3. How Do We Use Them?

ACUC RECREATIONAL DIVE TABLES / TABLES DE PLONGÉE RÉCRÉATIVE ACUC / TABLAS ACUC DE BUCEO RECREATIVO												
See warning in instructions / Voyez l'avertissement dans les instructions / Ver aviso en las instrucciones												
TABLE A: RESIDUAL NITROGEN GROUP (RNG) AND SAFETY OR DECOMPRESSION STOPS												
GROUPE D'AZOTE RÉSIDUEL (GAR) ET PALIERS DE SÉCURITÉ OU OBLIGATOIRES												
GRUPO DE NITROGENO RESIDUAL (GNR) Y PARADAS DE SEGURIDAD O DE DESCOMPRESION												
DIVE LENGTH IN MINUTES - (SAFETY OR DECO STOP) / TEMPS DE PLONGÉE EN MINUTES - (PALIER DE SÉCURITÉ OU DE DÉCOMPRESION)												
TIEMPO DE INMERSION EN MINUTOS (PARADA DE SEGURIDAD O DE DESCOMPRESION)												
D / P	30	60	90	120	150	180	240	300	360	420	480	600
6m/20'	30	60	90	120	150	180	240	300	360	420	480	600
9m/30'	30	45	60	90	100	120	150	180	190	210	240	270
12m/40'	22 (S)	30 (S)	40 (S)	60 (S)	70 (S)	80 (S)	90 (S)	120 (S)	130 (S)	150 (S)	160 (1)	170 (1)
15m/50'	18 (S)	25 (S)	30 (S)	40 (S)	50 (S)	60 (S)	75 (S)	85 (1)	95 (1)	105 (2)	115 (2)	124 (3)
18m/60'	14 (S)	20 (S)	25 (S)	30 (S)	40 (S)	50 (S)	60 (1)	70 (2)	80 (2)	85 (3)	92 (4)	
21m/70'	12 (S)	15 (S)	20 (S)	25 (S)	35 (S)	40 (1)	50 (2)	60 (5)	63 (5)	66 (6)		
24m/80'	10 (S)	13 (S)	15 (S)	20 (S)	25 (S)	29 (1)	35 (2)	48 (5)	52 (6)			
27m/90'	9 (S)	12 (S)	15 (S)	20 (S)	23 (1)	27 (2)	35 (5)	40 (6)	43 (6)			
30m/100'	7 (S)	10 (S)	12 (S)	15 (S)	18 (1)	21 (2)	25 (5)	29 (5)	36 (6)			
33m/110'	6 (S)	10 (S)	12 (S)	15 (1)	18 (2)	22 (5)	26 (6)	30 (6)				
36m/120'	5 (S)	8 (S)	10 (S)	12 (1)	15 (2)	19 (5)	25 (6)					
39m/130'	5 (S)	8 (S)	10 (1)	13 (2)		16 (5)	21 (6)					
42m/140'	5 (S)	7 (S)	9 (1)	11 (2)		14 (5)	18 (6)					
RNG GAR/GNR>	A	B	C	D	E	F	G	H	I	J	K	L
Deco Code:	(S)	(1)	(2)	(3)	(4)	(5)	(5)	10	10	10	10	10
Minutes:	3	5	10	15	20	5	10	6m 20'	3m 10'	6m 20'	3m 10'	3m 10'
D / P:	4.5m / 15'	3m / 10'	3m / 10'	3m / 10'	3m / 10'	3m / 10'	3m / 10'	3m / 10'	3m / 10'	3m / 10'	3m / 10'	3m / 10'

SESSION OBJECTIVES

Identify and utilize the ACUC Diving Tables to successfully complete the following:

1. Single non-repetitive dive
2. Repetitive dive
3. Multi-Level dive (discussion only)
4. Altitude diving (rule of 4%)
5. Discuss flying after diving
6. Review Decompression schedules

Decompression Theory

 As we know... compressed air, which we inhale during scuba diving, contains nitrogen and oxygen at the rate of 8:2

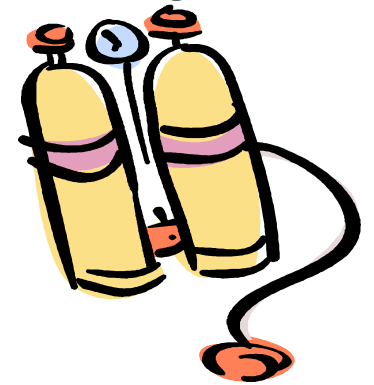

☺ The nitrogen we inhale is absorbed into our tissues under high pressure.

2. Why Do We Use Dive Tables?

To determine how **long** and how **deep** you can dive **WITHOUT** undue risk of **DCS**

DCS (decompression sickness)

ACUC Dive Tables

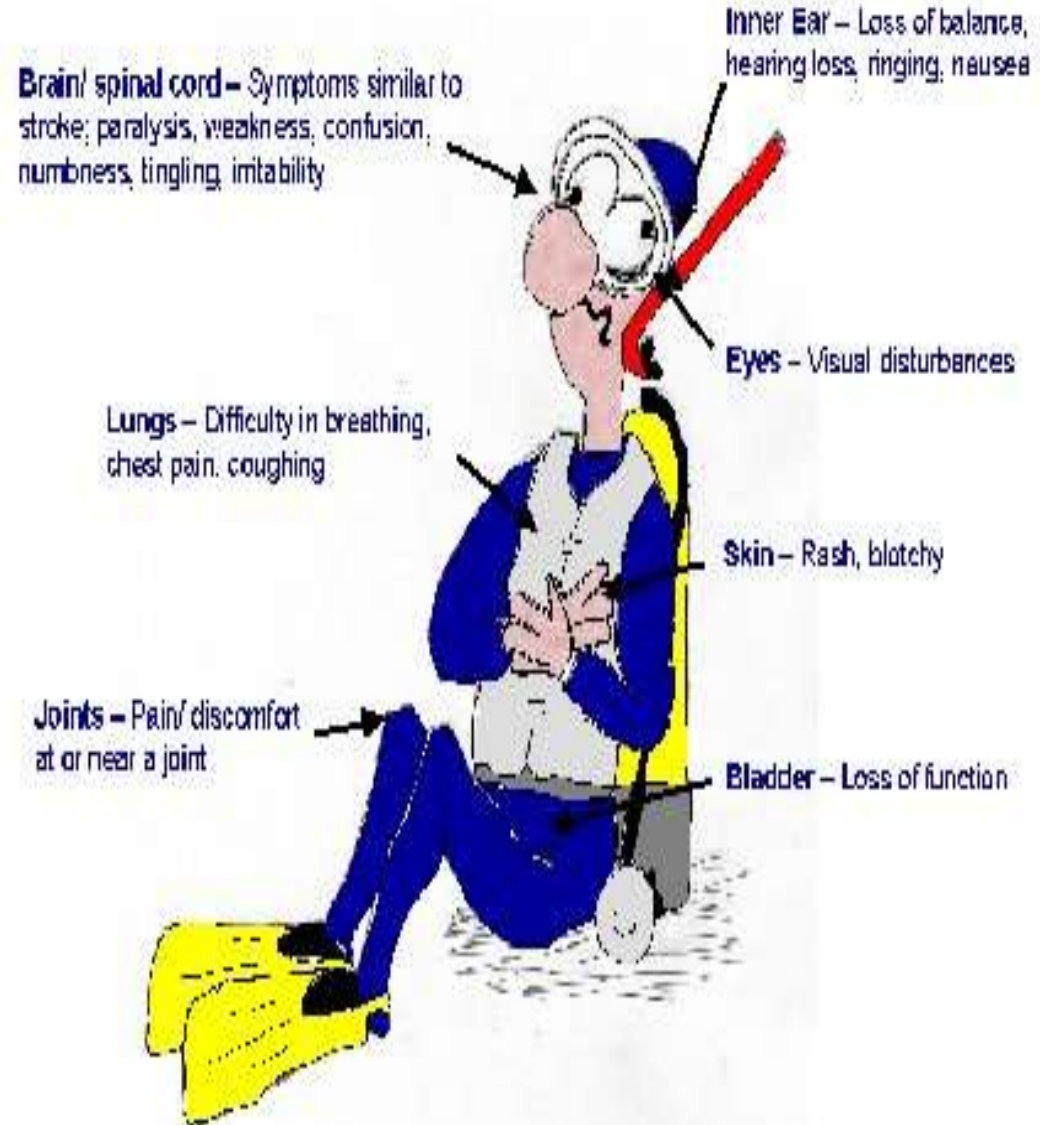

If we ascend without 'off-gassing' the nitrogen that has been dissolved into our tissues during diving, we may get ...

decompression sickness.



ACUC Dive Tables

PLEASE REMEMBER...

-  ***Every diver is different*** (age, physical fitness, metabolism, hydration, comfort level, dive conditions, etc.)
-  It is impossible to develop a set of Dive Tables that will ***guarantee freedom from Decompression Sickness.***
-  These tables provide general rules and guidelines.

3. How Do We Use Them?

 **This is where the water meets the diver...**
(so to speak)

 **The use of these tables is relatively easy and the more you use them the easier it gets and the safer your dives will be.**

ACUC Dive Tables

DEFINITIONS AND ACRONYMS

SD (Single Dive)

Any one dive conducted after a minimum surface interval as indicated in Row F/E/L in Table B on the ACUC Diving Tables.

RD (Repetitive Dive)

Any dive following a previous dive with a SI less than the time indicated in Row F/E/L in Table B on the ACUC Diving Tables.

RNG (Repetitive Nitrogen Group)

A letter designation assigned in Table A of the ACUC Diving Tables, in accordance with the depth and duration of a dive.

DR (Descent Rate)

The speed at which a divers travels to depth. It is recommended that divers not exceed at a rate of 75' (22m) per minute.

ACUC Dive Tables

DEFINITIONS AND ACRONYMS ... continued

AR (Ascent Rate)

The speed at which divers travel to the surface. This rate allows for the safe off gassing of some nitrogen without coming out of solution. The accepted ascent rate is 50' (15m) per minute, plus or minus 10' (3m) per minute. **The slower... the better !!**

BT (Bottom Time)

Calculated from the time a divers leaves the surface until beginning the final ascent to the surface.

ABT (Actual Bottom Time)

When doing repetitive dives, the BT of the actual dive taking place.

NPT (Nitrogen Penalty Time)

The calculated amount of nitrogen left in a diver's system after a previous dive minus the allowance for the Surface Interval.¹²

ACUC Dive Tables

DEFINITIONS AND ACRONYMS ... continued

TBT (Total Bottom Time)

Calculated by adding the ABT for the dive plus the NPT.

SIT (Surface Interval Time)

The amount of time spent on the surface before conducting another dive.

RDC (Repetitive Dive Column)

A column specific to the ACUC Diving Tables, having a R1 – R10 designation to assist in moving from Table B to Table

NDL (NO Decompression Limit)

The maximum amount of time for each depth in Table A that can be spent before a mandatory decompression stop (not including the Safety Stops) must be taken. This is the time indicated Yellow color (indicating caution) on Table A.

ACUC Dive Tables

DEFINITIONS AND ACRONYMS ... continued

SS (Safety Stop)

Strongly recommended for dives greater than 30' (9m) that do not require mandatory Decompression Stops. ACUC recommends a 3 min SS at a depth between 20' (6m) and 10' (3 m).

DS (Decompression Stop)

A mandatory stop to eliminate excess nitrogen accumulated from a dive exceeding the No-Decompression Time Limit. The diver is to spend the required time at the depth assigned for that profile.

NOTE:

Depth for Safety Stops and Decompression Stops are taken at mid-chest level for the times indicated.

ACUC Dive Tables

Color Codes

GREEN – “SAFE or SAFER”

YELLOW – “CAUTION”

RED/PINK – “DANGER”

ACUC RECREATIONAL DIVE TABLES / TABLES DE PLONGÉE RÉCRÉATIVE ACUC / TABLAS ACUC DE BUCEO RECREATIVO												
See warning in instructions / Voyez l'avertissement dans les instructions / Ver aviso en las instrucciones												
TABLE A: RESIDUAL NITROGEN GROUP (RNG) AND SAFETY OR DECOMPRESSION STOPS												
GROUPE D'AZOTE RÉSIDUEL (GAR) ET PALIERS DE SÉCURITÉ OU OBLIGATOIRES												
GRUPO DE NITROGENO RESIDUAL (GNR) Y PARADAS DE SEGURIDAD O DE DESCOMPRESION												
DIVE LENGTH IN MINUTES – (SAFETY OR DECO STOP) / TEMPS DE PLONGÉE EN MINUTES - (PALIER DE SÉCURITÉ OU DE DÉCOMPRESION)												
TIEMPO DE INMERSION EN MINUTOS (PARADA DE SEGURIDAD O DE DESCOMPRESION)												
D / P	30	60	90	120	150	180	240	300	360	420	480	600
6m/20'	30	60	90	120	150	180	240	300	360	420	480	600
9m/30'	30	45	60	90	100	120	150	180	190	210	240	270
12m/40'	22 (S)	30 (S)	40 (S)	60 (S)	70 (S)	80 (S)	90 (S)	120 (S)	130 (S)	150 (S)	160 (1)	170 (1)
15m/50'	18 (S)	25 (S)	30 (S)	40 (S)	50 (S)	60 (S)	75 (S)	85 (1)	95 (1)	105 (2)	115 (2)	124 (3)
18m/60'	14 (S)	20 (S)	25 (S)	30 (S)	40 (S)	50 (S)	60 (1)	70 (2)	80 (2)	85 (3)	92 (4)	
21m/70'	12 (S)	15 (S)	20 (S)	25 (S)	35 (S)	40 (1)	50 (2)	60 (5)	63 (5)	66 (6)		
24m/80'	10 (S)	13 (S)	15 (S)	20 (S)	25 (S)	29 (1)	35 (2)	48 (5)	52 (6)			
27m/90'	9 (S)	12 (S)	15 (S)	20 (S)	23 (1)	27 (2)	35 (5)	40 (6)	43 (6)			
30m/100'	7 (S)	10 (S)	12 (S)	15 (S)	18 (1)	21 (2)	25 (5)	29 (5)	36 (6)			
33m/110'	6 (S)	10 (S)	12 (S)	15 (1)	18 (2)	22 (5)	26 (6)	30 (6)				
36m/120'	6 (S)	8 (S)	10 (S)	12 (1)	15 (2)	19 (5)	25 (6)					
39m/130'	5 (S)	8 (S)	10 (1)	13 (2)		16 (5)	21 (6)					
42m/140'	5 (S)	7 (S)	9 (1)	11 (2)		14 (5)	18 (6)					
RNG GAR/GNR>	A	B	C	D	E	F	G	H	I	J	K	L
Deco Code:	(S)	(S)	(S)	(1)	(2)	(3)	(4)	(5)	(5)	(6)		
Minutes:	3	5	10	15	20	5	10	10	10	10	10	10
D / P:	4.5m / 15'	3m / 10'	3m / 10'	3m / 10'	3m / 10'	3m / 10'	3m / 10'	6m / 20'	3m / 10'	6m / 20'	3m / 10'	3m / 10'

ACUC Dive Tables

Table A: Residual Nitrogen Group (RNG) and Safety or Decompression Stops

ACUC RECREATIONAL DIVE TABLES / TABLES DE PLONGÉE RÉCRÉATIVE ACUC / TABLAS ACUC DE BUCEO RECREATIVO
 See warning in instructions / Voyez l'avertissement dans les instructions / Ver aviso en las instrucciones
TABLE A: RESIDUAL NITROGEN GROUP (RNG) AND SAFETY OR DECOMPRESSION STOPS
 GROUPE D'AZOTE RÉSIDUEL (GAR) ET PALIERS DE SÉCURITÉ OU OBLIGATOIRES
 GRUPO DE NITROGENO RESIDUAL (GNR) Y PARADAS DE SEGURIDAD O DE DESCOMPRESION

DIVE LENGTH IN MINUTES - (SAFETY OR DECO STOP) / TEMPS DE PLONGÉE EN MINUTES - (PALIER DE SÉCURITÉ OU DE DÉCOMPRESION)
 TIEMPO DE INMERSION EN MINUTOS (PARADA DE SEGURIDAD O DE DESCOMPRESION)

D / P	30	60	90	120	150	180	240	300	360	420	480	600
6m/20'	30	60	90	120	150	180	240	300	360	420	480	600
9m/30'	30	45	60	90	100	120	150	180	190	210	240	270
12m/40'	22 (S)	30 (S)	40 (S)	60 (S)	70 (S)	80 (S)	90 (S)	120 (S)	130 (S)	150 (S)	160 (1)	170 (1)
15m/50'	18 (S)	25 (S)	30 (S)	40 (S)	50 (S)	60 (S)	75 (S)	85 (1)	95 (1)	105 (2)	115 (2)	124 (3)
18m/60'	14 (S)	20 (S)	25 (S)	30 (S)	40 (S)	50 (S)	60 (1)	70 (2)	80 (2)	85 (3)	92 (4)	
21m/70'	12 (S)	15 (S)	20 (S)	25 (S)	35 (S)	40 (1)	50 (2)	60 (5)	63 (5)	66 (6)		
24m/80'	10 (S)	13 (S)	15 (S)	20 (S)	25 (S)	29 (1)	35 (2)	48 (5)	52 (6)			
27m/90'	9 (S)	12 (S)	15 (S)	20 (S)	23 (1)	27 (2)	35 (5)	40 (6)	43 (6)			
30m/100'	7 (S)	10 (S)	12 (S)	15 (S)	18 (1)	21 (2)	25 (5)	29 (5)	36 (6)			
33m/110'	6 (S)	10 (S)	12 (S)	15 (1)	18 (2)	22 (5)	26 (6)	30 (6)				
36m/120'	6 (S)	8 (S)	10 (S)	12 (1)	15 (2)	19 (5)	25 (6)					
39m/130'	5 (S)	8 (S)	10 (1)	13 (2)		16 (5)	21 (6)					
42m/140'	5 (S)	7 (S)	9 (1)	11 (2)		14 (5)	18 (6)					
RNG GAR/GNR>	A	B	C	D	E	F	G	H	I	J	K	L
Deco Code:	(S)	(S)	(1)	(1)	(2)	(3)	(4)	(4)	(5)	(5)	(6)	(6)
Minutes:	3	3	5	5	10	15	20	20	5	10	10	10
D / P:	4.5m / 15'	4.5m / 15'	3m / 10'	3m / 10'	3m / 10'	3m / 10'	3m / 10'	3m / 10'	6m / 20'	3m / 10'	6m / 20'	3m / 10'

RNG

ACUC Dive Tables

Table B: Surface Interval Group (SIG)

TABLE B: SURFACE INTERVAL GROUP (SIG) / GROUPE D'INTERVALLE DE SURFACE (GIS) / GRUPO DE INTERVALO EN SUPERFICIE (GIS)

RNG/GAR/GNR > SIT / TIS	A	B	C	D	E	F	G	H	I	J	K	L
0:15 – 0:29	R4	R5	R6	R8	R9	R10						
0:30 – 0:59	R2	R3	R4	R5	R6	R7	R9					
1:00 – 1:29	R1	R2	R3	R4	R5	R6	R7	R9	R10			
1:30 – 1:59	R1	R2	R2	R3	R4	R5	R6	R7	R8	R9	R10	
2:00 – 2:59	R1	R2	R2	R3	R3	R4	R5	R6	R7	R8	R9	R10
3:00 – 3:59	R1	R1	R2	R2	R3	R3	R4	R5	R5	R6	R7	R7
4:00 – 5:59	R1	R1	R1	R2	R2	R3	R3	R4	R4	R5	R5	R6
6:00 – 8:59	R1	R1	R1	R1	R2	R2	R2	R3	R3	R3	R3	R4
9:00 – 11:59	R1	R1	R1	R1	R1	R1	R1	R1	R1	R2	R2	R2
12:00 – 14:59	F/E/L	F/E/L	F/E/L	F/E/L	R1	R1	R1	R1	R1	R1	R1	R1
15:00 – 18:00	F/E/L	F/E/L	F/E/L	F/E/L	F/E/L	F/E/L	F/E/L	R1	R1	R1	R1	R1

SIT

SIG

RNG

ACUC Dive Tables

Table C: Maximum NO Decompression Time (MNDT) and Nitrogen Penalty Times (NPT)

TABLE C: MAXIMUM NO DECOMPRESSION TIME (MNDT) AND NITROGEN PENALTY TIMES (NPT) FOR SUBSEQUENT DIVES
 TEMPS MAXIMAL DE NON-DÉCOMPRESSION (TMND) ET DE TEMPS DE PÉNALITÉ D'AZOTE (TPA) POUR LES PLONGÉES SUBSÉQUENTES
 TIEMPO MAXIMO DE NO DESCOMPRESION (TMND) Y TIEMPO DE PENALTY DE NITROGENO (TPN) PARA LAS INMERSIONES SIGUIENTES

RD/PR > SIG / GIS	6m 20'	9m 30'	12m 40'	15m 50'	18m 60'	21m 70'	24m 80'	27m 90'	30m 100'	33m 110'	36m 120'	39m 130'	42m 140'
R1	665 55	272 28	136 14	60 15	40 10	30 5	20 5	16 4	13 2	10 2	8 2	7 1	6 1
R2	600 120	250 50	125 25	55 20	35 15	25 10	18 7	14 6	11 4	9 3	7 3	6 2	5 2
R3	554 166	230 70	115 35	50 25	31 19	21 14	16 9	12 8	10 5	8 4	7 3	6 2	5 2
R4	515 205	214 86	107 43	45 30	29 21	19 16	15 10	11 9	9 6	8 4	6 4	5 3	5 2
R5	480 240	200 100	100 50	41 34	27 23	18 17	14 11	11 9	9 6	7 5	6 4	5 3	4 3
R6	450 270	187 113	93 57	38 37	26 24	17 18	13 12	10 10	8 7	7 5	6 4	5 3	4 3
R7	424 296	175 124	88 62	36 39	24 26	16 19	12 13	9 11	8 7	6 6	5 5	4 4	4 3
R8	400 320	163 134	83 67	34 41	23 27	15 21	12 13	9 11	7 8	6 6	5 5	4 4	3 4
R9	379 341	151 143	78 72	32 43	22 28	14 21	11 14	8 12	7 8	6 6	5 5	4 4	3 4
R10	360 360	150 150	75 75	31 44	21 29	13 21	11 14	8 12	7 8	6 6	5 5	4 4	3 4

MNDT

NPT

ACUC Dive Tables

Depth of dive
33 feet
for
60 minutes

What is the
Maximum BT?

Can this dive
be made as a
NDL dive?

What is the
RNG after this
dive? **D**

YES

ACUC RECREATIONAL DIVE TABLES / TABLES DE PLONGÉE RÉCRÉATIVE ACUC / TABLAS ACUC DE BUCEO RECREATIVO
See warning in instructions / Voyez l'avertissement dans les instructions / Ver aviso en las instrucciones

ACUC

TABLE A: RESIDUAL NITROGEN GROUP (RNG) AND SAFETY OR DECOMPRESSION STOPS
GROUPE D'AZOTE RÉSIDUEL (GAR) ET PALIERS DE SÉCURITÉ OU OBLIGATOIRES
GRUPO DE NITRÓGENO RESIDUAL (GNR) Y PARADAS DE SEGURIDAD O DE DESCOMPRESIÓN

DIVE LENGTH IN MINUTES - (SAFETY OR DECO STOP) / TEMPS DE PLONGÉE EN MINUTES - (PALIER DE SÉCURITÉ OU DE DÉCOMPRESSION)
TIEMPO DE INMERSION EN MINUTOS (PARADA DE SEGURIDAD O DE DESCOMPRESIÓN)

D / P	30	60	90	120	150	180	240	300	360	420	480	600	
6m/20'	30	60	90	120	150	180	240	300	360	420	480	600	
9m/30'	30	45	60	90	100	120	150	180	190	210	240	270	
12m/40'	22 (S)	30 (S)	40 (S)	60 (S)	70 (S)	80 (S)	90 (S)	120 (S)	130 (S)	150 (S)	160 (1)	170 (1)	
15m/50'	18 (S)	25 (S)	30 (S)	40 (S)	50 (S)	60 (S)	75 (S)	85 (1)	95 (1)	105 (2)	115 (2)	124 (3)	
18m/60'	14 (S)	20 (S)	25 (S)	30 (S)	40 (S)	50 (S)	60 (1)	70 (2)	80 (2)	85 (3)	92 (4)		
21m/70'	12 (S)	15 (S)	20 (S)	25 (S)	35 (S)	40 (1)	50 (2)	60 (5)	63 (5)	66 (6)			
24m/80'	10 (S)	13 (S)	15 (S)	20 (S)	25 (S)	29 (1)	35 (2)	48 (5)	52 (6)				
27m/90'	9 (S)	12 (S)	15 (S)	20 (S)	23 (1)	27 (2)	35 (5)	40 (6)	43 (6)				
30m/100'	7 (S)	10 (S)	12 (S)	15 (S)	18 (1)	21 (2)	25 (5)	29 (5)	36 (6)				
33m/110'	6 (S)	10 (S)	12 (S)	15 (1)	18 (2)	22 (5)	26 (6)	30 (6)					
36m/120'	6 (S)	8 (S)	10 (S)	12 (1)	15 (2)	19 (5)	25 (6)						
39m/130'	5 (S)	8 (S)	10 (1)	13 (2)		16 (5)	21 (6)						
42m/140'	5 (S)	7 (S)	9 (1)	11 (2)		14 (5)	18 (6)						
RNG GAR/GNR>	A	B	C	D	E	F	G	H	I	J	K	L	
Deco Code:	(S)	(1)	(2)	(3)	(4)	(5)	(6)						
Minutes:	3	5	10	15	20	5	10	10	10	10	10	10	
D / P:	4.5m / 15'	3m / 10'	3m / 10'	3m / 10'	3m / 10'	3m / 10'	3m / 10'	3m / 10'	3m / 10'	6m / 20'	3m / 10'	6m / 20'	3m / 10'

ACUC Dive Tables

Depth of dive
60 feet
for
57 minutes

What is the
Maximum BT?

Can this dive
be made as a
NDL dive?

What is the
RNG after this
dive? **G**

NO

ACUC RECREATIONAL DIVE TABLES / TABLES DE PLONGÉE RÉCRÉATIVE ACUC / TABLAS ACUC DE BUCEO RECREATIVO

See warning in instructions / Voyez l'avertissement dans les instructions / Ver aviso en las instrucciones



TABLE A: RESIDUAL NITROGEN GROUP (RNG) AND SAFETY OR DECOMPRESSION STOPS

GRUPE D'AZOTE RÉSIDUEL (GAR) ET PALIERS DE SÉCURITÉ OU OBLIGATOIRES

GRUPO DE NITRÓGENO RESIDUAL (GNR) Y PARADAS DE SEGURIDAD O DE DESCOMPRESIÓN

DIVE LENGTH IN MINUTES - (SAFETY OR DECO STOP) / TEMPS DE PLONGÉE EN MINUTES - (PALIER DE SÉCURITÉ OU DE DÉCOMPRESSION)

TIEMPO DE INMERSION EN MINUTOS (PARADA DE SEGURIDAD O DE DESCOMPRESIÓN)

D / P	DIVE LENGTH IN MINUTES - (SAFETY OR DECO STOP) / TEMPS DE PLONGÉE EN MINUTES - (PALIER DE SÉCURITÉ OU DE DÉCOMPRESSION)											
	TIEMPO DE INMERSION EN MINUTOS (PARADA DE SEGURIDAD O DE DESCOMPRESIÓN)											
6m/20'	30	60	90	120	150	180	240	300	360	420	480	600
9m/30'	30	45	60	90	100	120	150	180	190	210	240	270
12m/40'	22 (S)	30 (S)	40 (S)	60 (S)	70 (S)	80 (S)	90 (S)	120 (S)	130 (S)	150 (S)	160 (1)	170 (1)
15m/50'	18 (S)	25 (S)	30 (S)	40 (S)	50 (S)	60 (S)	75 (S)	85 (1)	95 (1)	105 (2)	115 (2)	124 (3)
18m/60'	14 (S)	20 (S)	25 (S)	30 (S)	40 (S)	50 (S)	60 (1)	70 (2)	80 (2)	85 (3)	92 (4)	
21m/70'	12 (S)	15 (S)	20 (S)	25 (S)	35 (S)	45 (1)	50 (2)	60 (5)	63 (5)	66 (6)		
24m/80'	10 (S)	13 (S)	15 (S)	20 (S)	25 (S)	29 (1)	35 (2)	48 (5)	52 (6)			
27m/90'	9 (S)	12 (S)	15 (S)	20 (S)	23 (1)	27 (2)	35 (5)	40 (6)	43 (6)			
30m/100'	7 (S)	10 (S)	12 (S)	15 (S)	18 (1)	21 (2)	25 (5)	29 (5)	36 (6)			
33m/110'	6 (S)	10 (S)	12 (S)	15 (1)	18 (2)	22 (5)	26 (6)	30 (6)				
36m/120'	6 (S)	8 (S)	10 (S)	12 (1)	15 (2)	19 (5)	25 (6)					
39m/130'	5 (S)	8 (S)	10 (1)	13 (2)		16 (5)	21 (6)					
42m/140'	5 (S)	7 (S)	9 (1)	11 (2)		14 (5)	18 (6)					
RNG GAR/GNR>	A	B	C	D	E	F	G	H	I	J	K	L
Deco Code:	(S)	(1)	(2)	(3)	(4)	(5)	(6)					
Minutes:	3	5	10	15	20	5	10	10	10	10	10	10
D / P:	4.5m / 15'	3m / 10'	3m / 10'	3m / 10'	3m / 10'	3m / 10'	3m / 10'	20'	10'	20'	20'	10'

ACUC Dive Tables

Depth of dive
89 feet
for
22 minutes

What is the
Maximum BT?

Can this dive
be made as a
NDL dive?

What is the
RNG after this
dive? **E**

NO

ACUC RECREATIONAL DIVE TABLES / TABLES DE PLONGÉE RÉCRÉATIVE ACUC / TABLAS ACUC DE BUCEO RECREATIVO

See warning in instructions / Voyez l'avertissement dans les instructions / Ver aviso en las instrucciones



TABLE A: RESIDUAL NITROGEN GROUP (RNG) AND SAFETY OR DECOMPRESSION STOPS GROUPE D'AZOTE RÉSIDUEL (GAR) ET PALIERS DE SÉCURITÉ OU OBLIGATOIRES GRUPO DE NITRÓGENO RESIDUAL (GNR) Y PARADAS DE SEGURIDAD O DE DESCOMPRESIÓN

DIVE LENGTH IN MINUTES - (SAFETY OR DECO STOP) / TEMPS DE PLONGÉE EN MINUTES - (PALIER DE SÉCURITÉ OU DE DÉCOMPRESSION)
TIEMPO DE INMERSION EN MINUTOS (PARADA DE SEGURIDAD O DE DESCOMPRESIÓN)

D / P	30	45	60	90	120	150	180	240	300	360	420	480	600
6m/20'	30	45	60	90	120	150	180	240	300	360	420	480	600
9m/30'	30	45	60	90	100	120	150	180	190	210	240	270	
12m/40'	22 (S)	30 (S)	40 (S)	60 (S)	70 (S)	80 (S)	90 (S)	120 (S)	130 (S)	150 (S)	160 (1)	170 (1)	
15m/50'	18 (S)	25 (S)	30 (S)	40 (S)	50 (S)	60 (S)	75 (S)	85 (1)	95 (1)	105 (2)	115 (2)	124 (3)	
18m/60'	14 (S)	20 (S)	25 (S)	30 (S)	40 (S)	50 (S)	60 (1)	70 (2)	80 (2)	85 (3)	92 (4)		
21m/70'	12 (S)	15 (S)	20 (S)	25 (S)	35 (S)	40 (1)	50 (2)	60 (5)	63 (5)	66 (6)			
24m/80'	10 (S)	13 (S)	15 (S)	20 (S)	25 (S)	29 (1)	35 (2)	48 (5)	52 (6)				
27m/90'	9 (S)	12 (S)	15 (S)	20 (S)	23 (1)	27 (2)	35 (5)	40 (6)	43 (6)				
30m/100'	7 (S)	10 (S)	12 (S)	15 (S)	18 (1)	21 (2)	25 (5)	29 (5)	36 (6)				
33m/110'	6 (S)	10 (S)	12 (S)	15 (1)	18 (2)	22 (5)	26 (6)	30 (6)					
36m/120'	6 (S)	8 (S)	10 (S)	12 (1)	15 (2)	19 (5)	25 (6)						
39m/130'	5 (S)	8 (S)	10 (1)	13 (2)		16 (5)	21 (6)						
42m/140'	5 (S)	7 (S)	9 (1)	11 (2)		14 (5)	18 (6)						
RNG GAR/GNR>	A	B	C	D	E	F	G	H	I	J	K	L	
Deco Code:	(S)	(1)	(2)	(3)	(4)	(5)	(6)						
Minutes:	3	5	10	15	20	5	10	10	10				
D / P:	4.5m / 15'	3m / 10'	3m / 10'	3m / 10'	3m / 10'	6m / 20'	3m / 10'	6m / 20'	3m / 10'				

ACUC Dive Tables

Depth of dive
40 feet
for
85 minutes

What is the
Maximum BT?

Can this dive
be made as a
NDL dive?

What is the
RNG after this
dive? **G**

YES

ACUC RECREATIONAL DIVE TABLES / TABLES DE PLONGÉE RÉCRÉATIVE ACUC / TABLAS ACUC DE BUCEO RECREATIVO

See warning in instructions / Voyez l'avertissement dans les instructions / Ver aviso en las instrucciones



TABLE A: RESIDUAL NITROGEN GROUP (RNG) AND SAFETY OR DECOMPRESSION STOPS

GRUPE D'AZOTE RÉSIDUEL (GAR) ET PALIERS DE SÉCURITÉ OU OBLIGATOIRES

GRUPO DE NITROGENO RESIDUAL (GNR) Y PARADAS DE SEGURIDAD O DE DESCOMPRESION

DIVE LENGTH IN MINUTES - (SAFETY OR DECO STOP) / TEMPS DE PLONGÉE EN MINUTES - (PALIER DE SÉCURITÉ OU DE DÉCOMPRESSION)
TIEMPO DE INMERSION EN MINUTOS (PARADA DE SEGURIDAD O DE DESCOMPRESION)

D / P	30	45	60	90	120	150	180	240	300	360	420	480	600
6m/20'	30	45	60	90	120	150	180	240	300	360	420	480	600
9m/30'	30	45	60	90	90	100	120	150	180	190	210	240	270
12m/40'	22 (S)	30 (S)	40 (S)	60 (S)	70 (S)	80 (S)	90 (S)	120 (S)	130 (S)	150 (S)	160 (1)	170 (1)	
15m/50'	18 (S)	25 (S)	30 (S)	40 (S)	50 (S)	60 (S)	75 (S)	85 (1)	95 (1)	105 (2)	115 (2)	124 (3)	
18m/60'	14 (S)	20 (S)	25 (S)	30 (S)	40 (S)	50 (S)	60 (1)	70 (2)	80 (2)	85 (3)	92 (4)		
21m/70'	12 (S)	15 (S)	20 (S)	25 (S)	35 (S)	40 (1)	50 (2)	60 (5)	63 (5)	66 (6)			
24m/80'	10 (S)	13 (S)	15 (S)	20 (S)	25 (S)	29 (1)	35 (2)	48 (5)	52 (6)				
27m/90'	9 (S)	12 (S)	15 (S)	20 (S)	23 (1)	27 (2)	35 (5)	40 (6)	43 (6)				
30m/100'	7 (S)	10 (S)	12 (S)	15 (S)	18 (1)	21 (2)	25 (5)	29 (5)	36 (6)				
33m/110'	6 (S)	10 (S)	12 (S)	15 (1)	18 (2)	22 (5)	26 (6)	30 (6)					
36m/120'	6 (S)	8 (S)	10 (S)	12 (1)	15 (2)	19 (5)	25 (6)						
39m/130'	5 (S)	8 (S)	10 (1)	13 (2)		16 (5)	21 (6)						
42m/140'	5 (S)	7 (S)	9 (1)	11 (2)		14 (5)	18 (6)						
RNG GAR/GNR>	A	B	C	D	E	F	G	H	I	J	K	L	
Deco Code:	(S)	(1)	(2)	(3)	(4)	(5)	(6)						
Minutes:	3	5	10	15	20	5	10	10	10	10	10	10	10
D / P:	4.5m / 15'	3m / 10'	3m / 10'	3m / 10'	3m / 10'	3m / 10'	3m / 10'	3m / 10'	3m / 10'	20'	10'	20'	10'

ACUC Dive Tables

Surface Interval
 ___ Hr. ___ min.

SIG _____

RNG _____

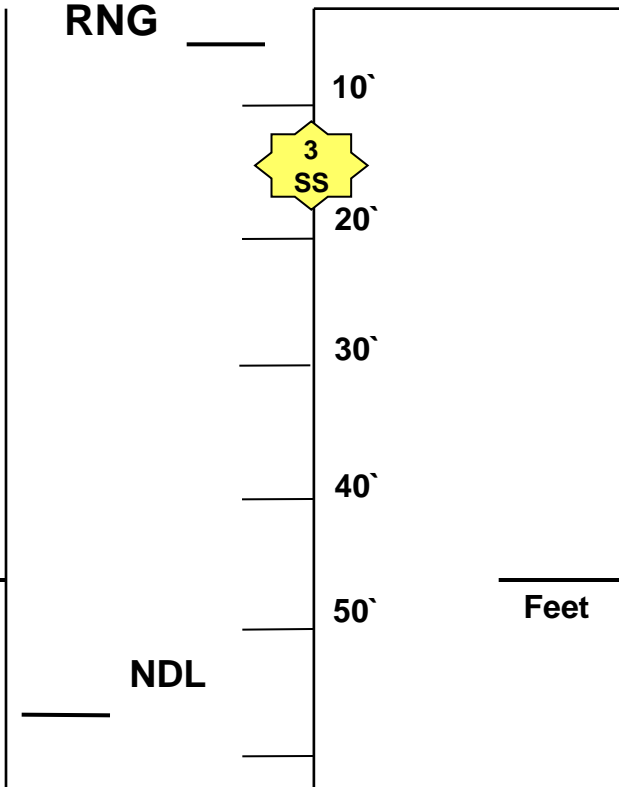

___ BT

Surface Interval
 ___ Hr. ___ min.

SIG _____

RNG _____

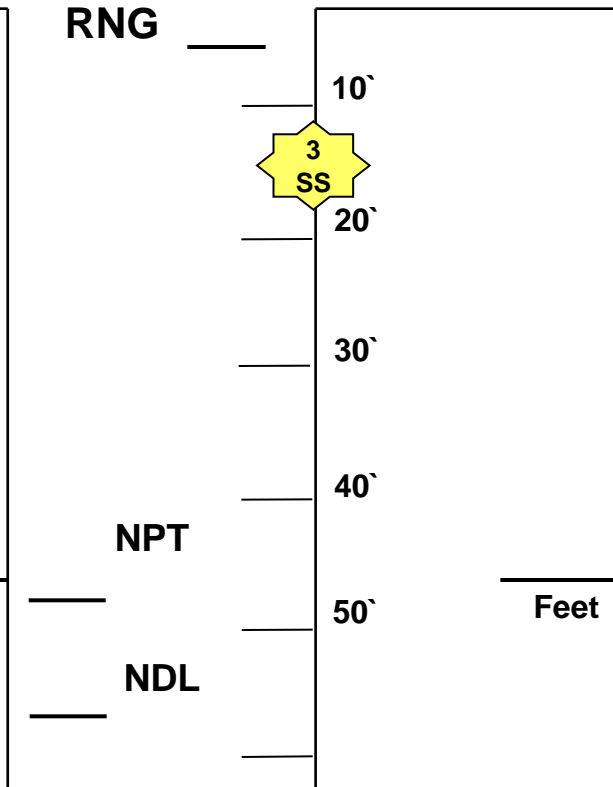

___ ABT
 + ___ NPT
 ___ TBT

RNG _____

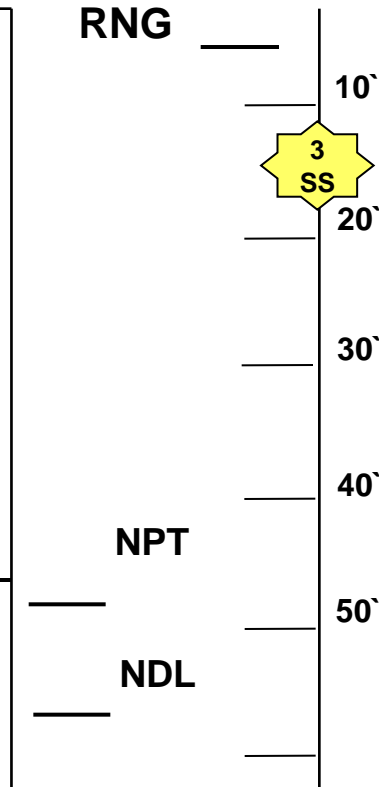

___ ABT
 + ___ NPT
 ___ TBT

ACUC Dive Tables

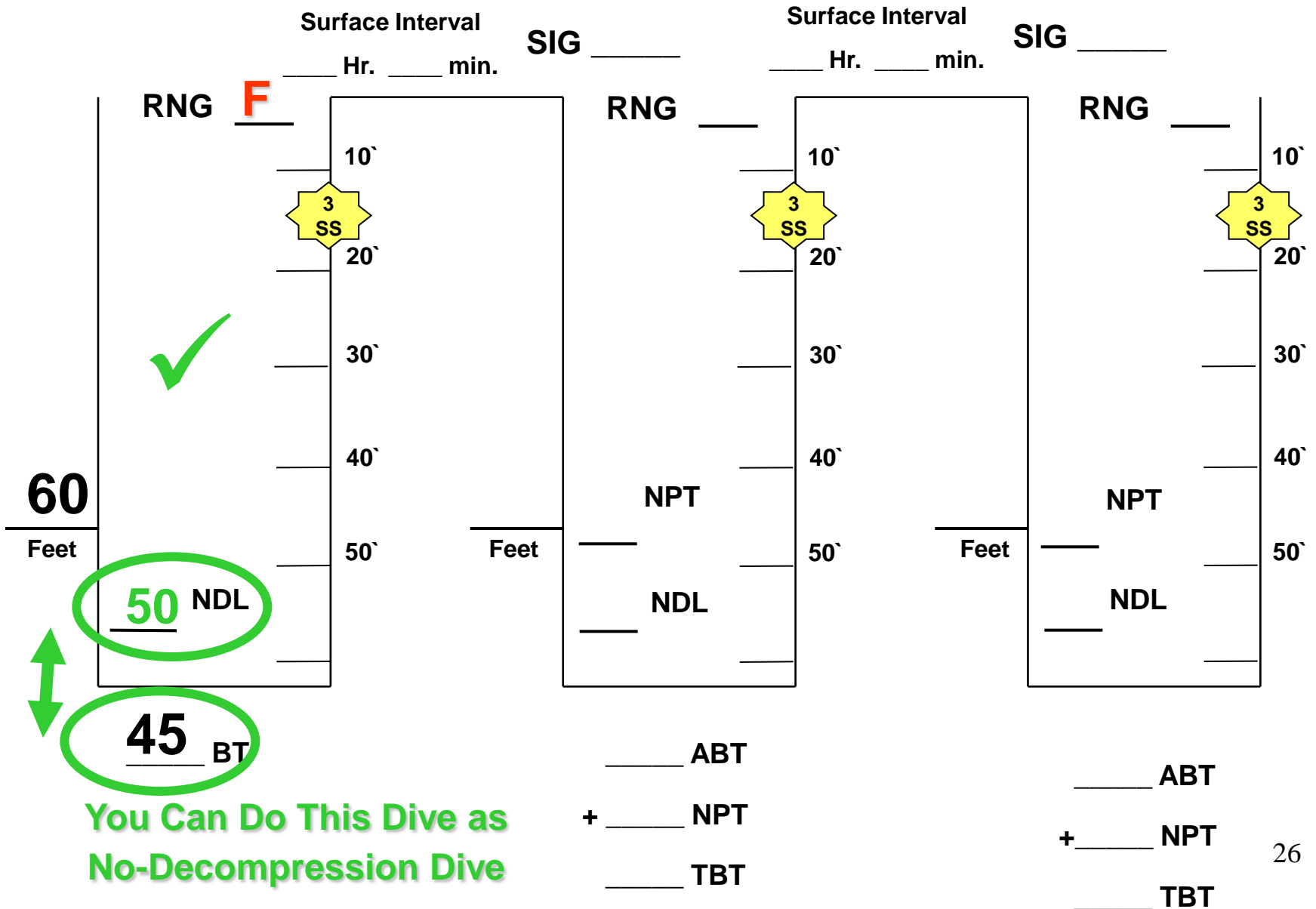

ACUC Dive Tables

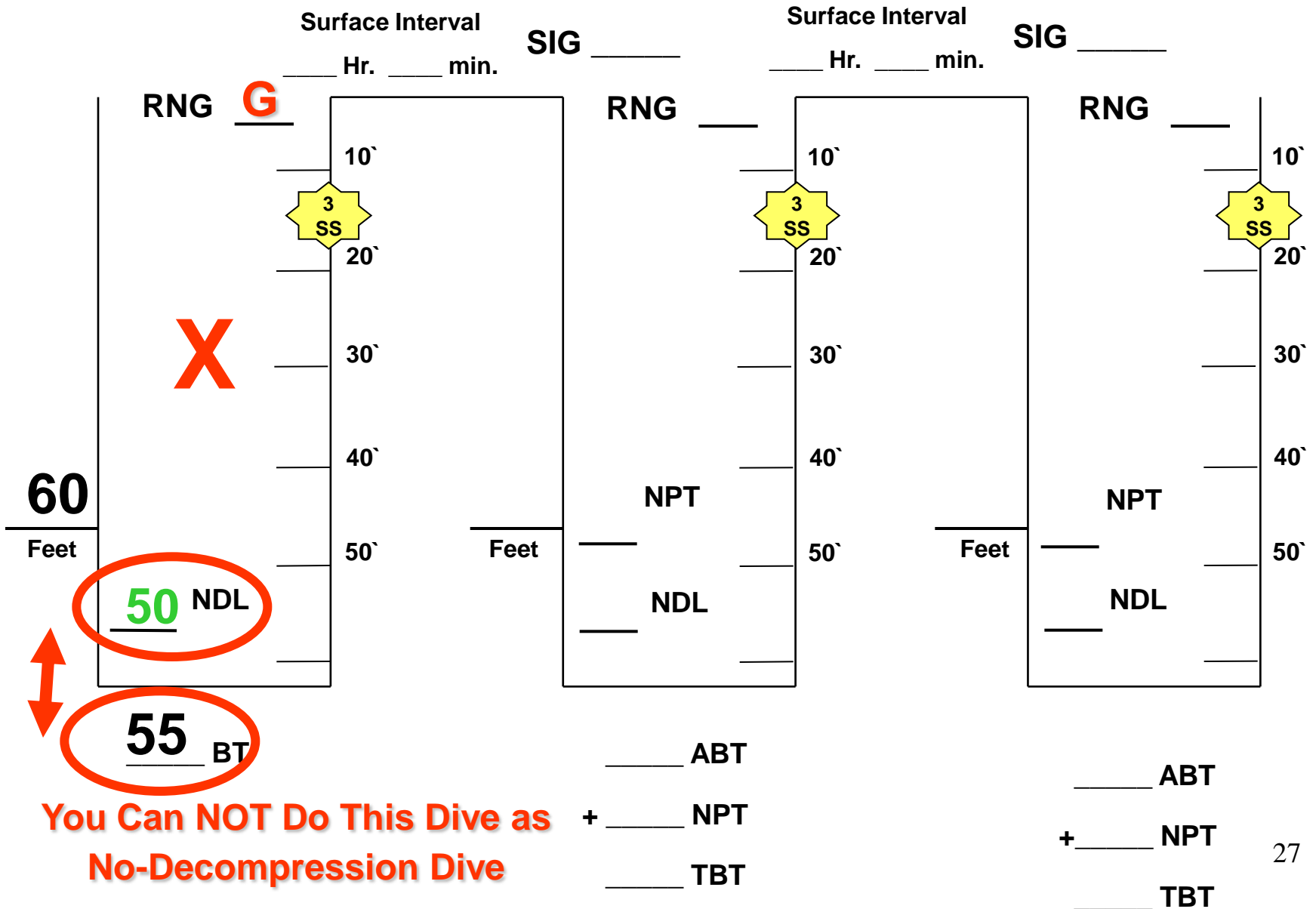

ACUC Dive Tables

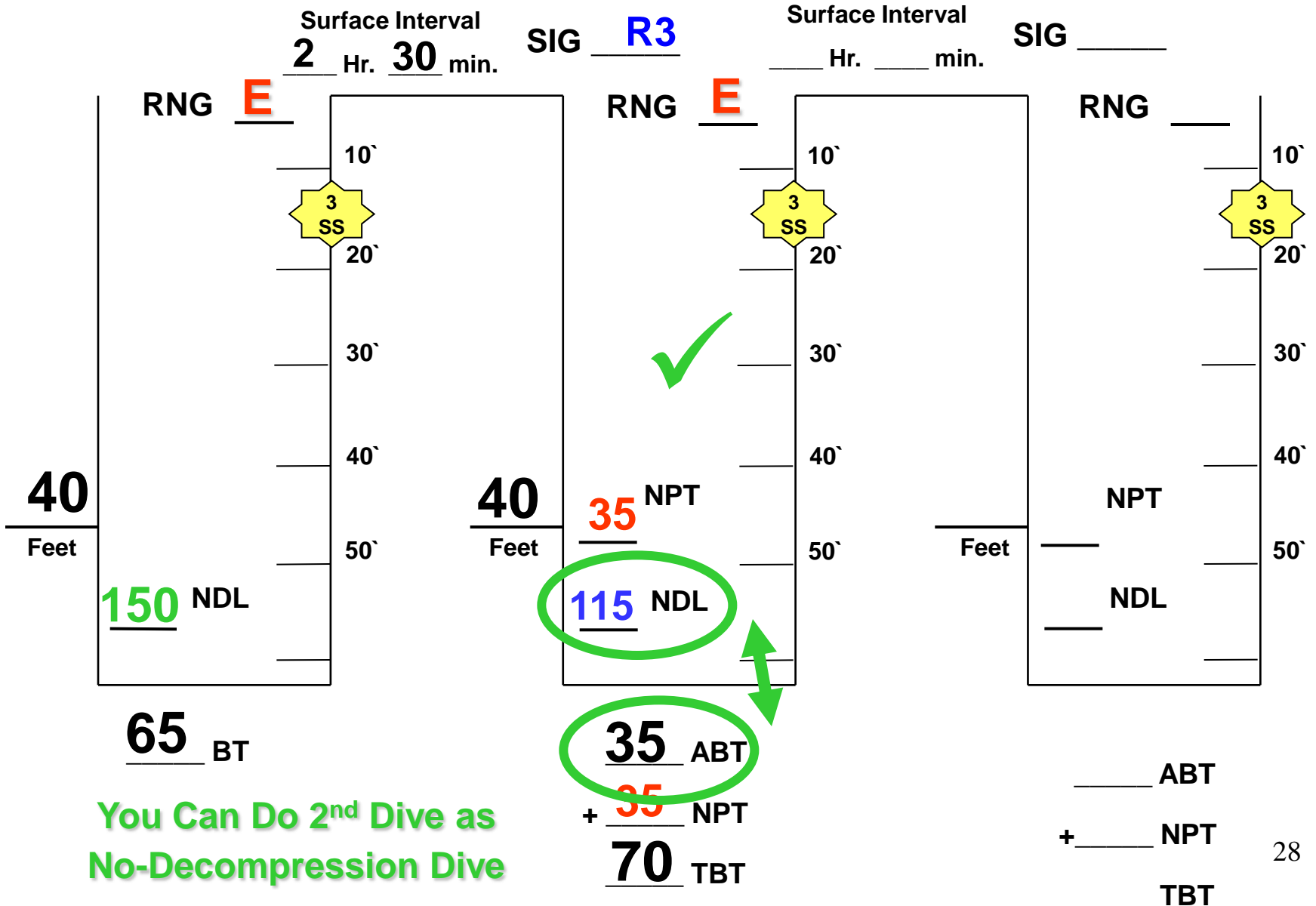

ACUC Dive Tables

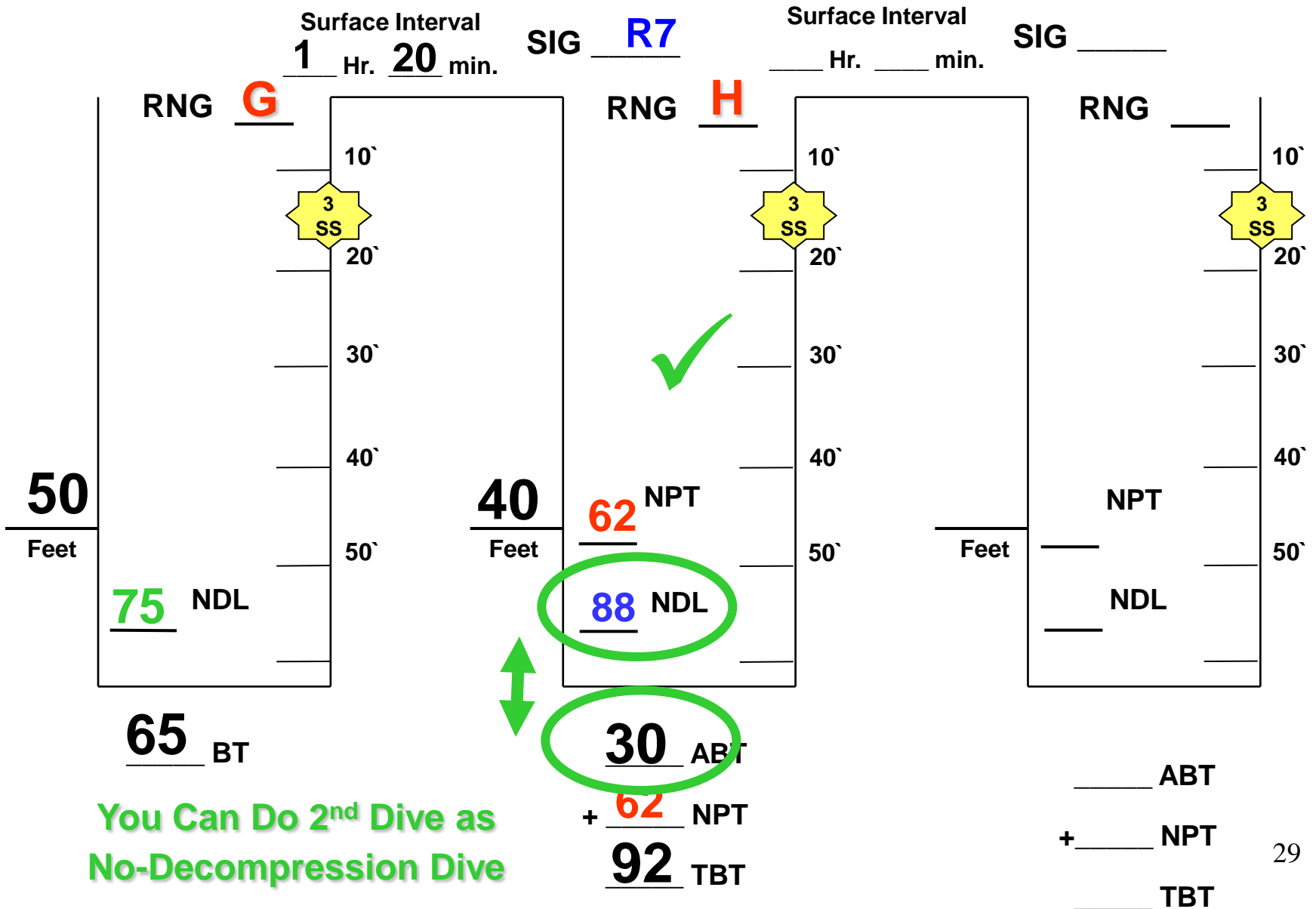

ACUC Dive Tables

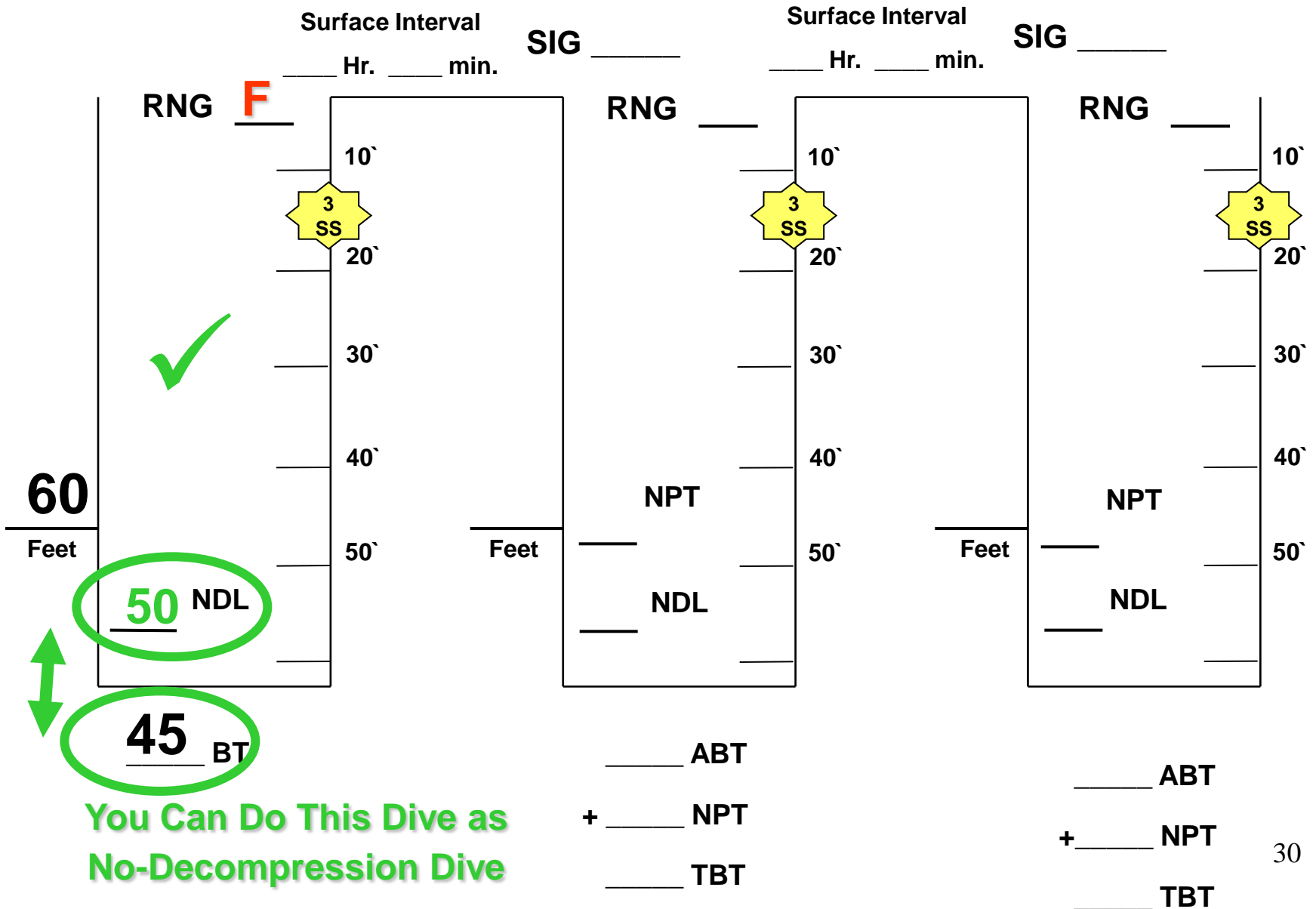

Air Sport Dive Table Worksheet

Surface Interval
2 Hr. 30 min.

SIG R3

Surface Interval
1 Hr. 00 min.

SIG R5

RNG E

RNG E

RNG E

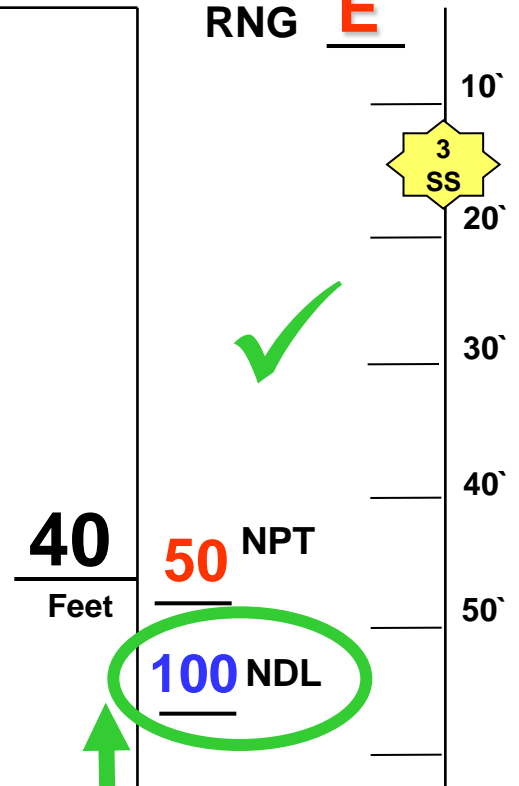
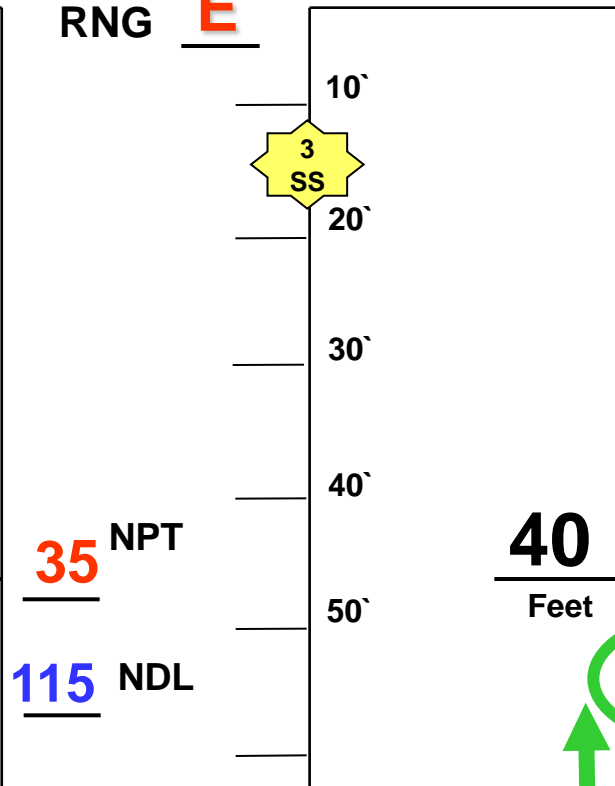
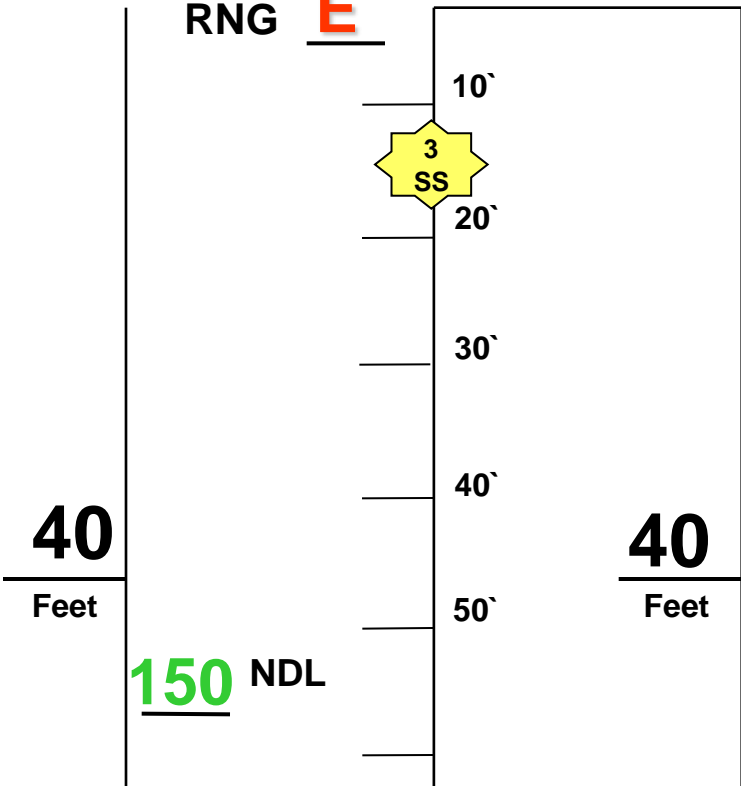

65 BT

35 ABT

20 ABT

You Can Do 3rd Dive as
No-Decompression Dive

+ 35 NPT

+ 50 NPT

70 TBT

70 TBT

Air Sport Dive Table Worksheet

Surface Interval
1 Hr. 30 min.

SIG R4

Surface Interval
1 Hr. 00 min.

SIG R7

RNG E

RNG G

RNG _____

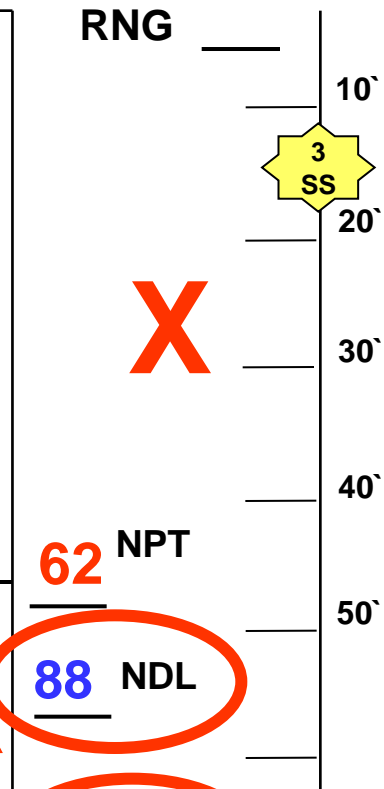
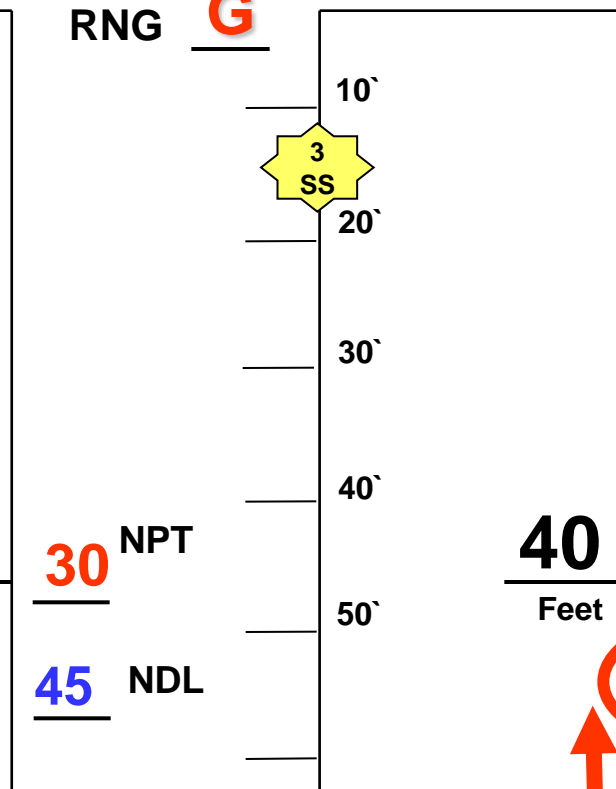
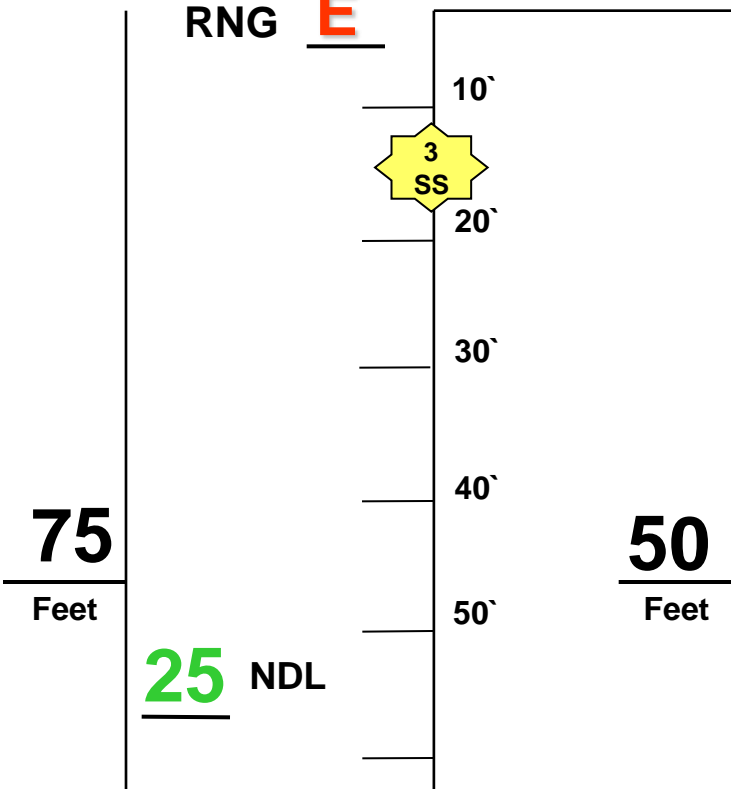

25 BT

45 ABT

90 ABT

Can Not Do 3rd Dive as
No-Decompression Dive

+ 30 NPT
75 TBT

+ 62 NPT
152 TBT

Air Sport Dive Table Worksheet

Surface Interval
1 Hr. **30** min.

SIG R4

Surface Interval
 ___ Hr. ___ min.

SIG _____

RNG **E**

RNG **G**

RNG _____

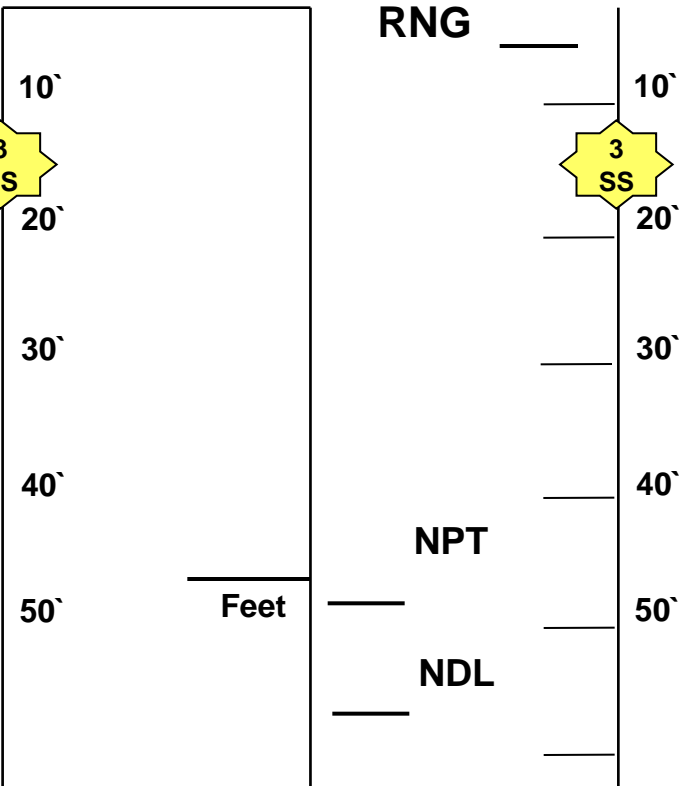
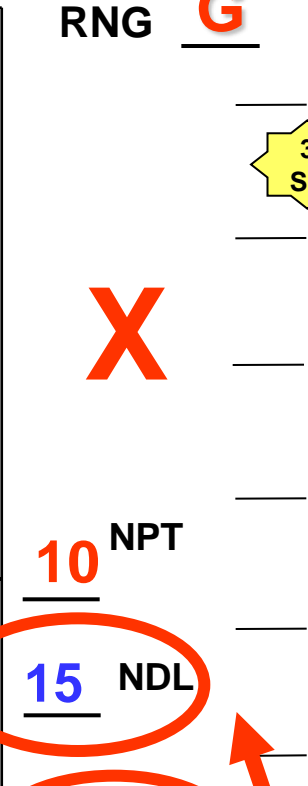
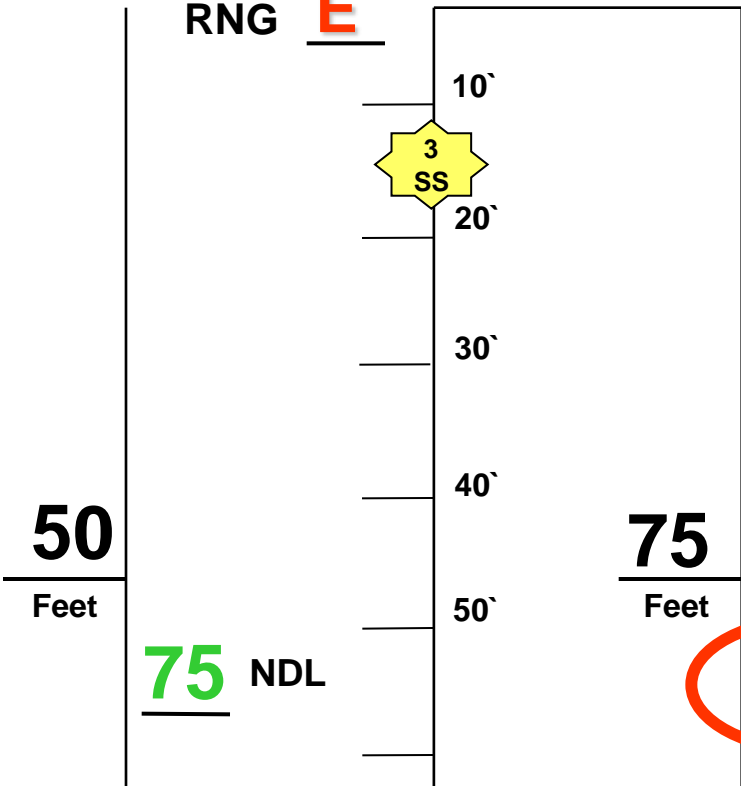

45 BT

25 APT

___ ABT

Can Not Do 2ND Dive as
 No-Decompression Dive

+ 10 NPT

+ ___ NPT

35 TBT

___ TBT

Air Sport Dive Table Worksheet

Surface Interval
2 Hr. 00 min.

SIG R3

RNG D

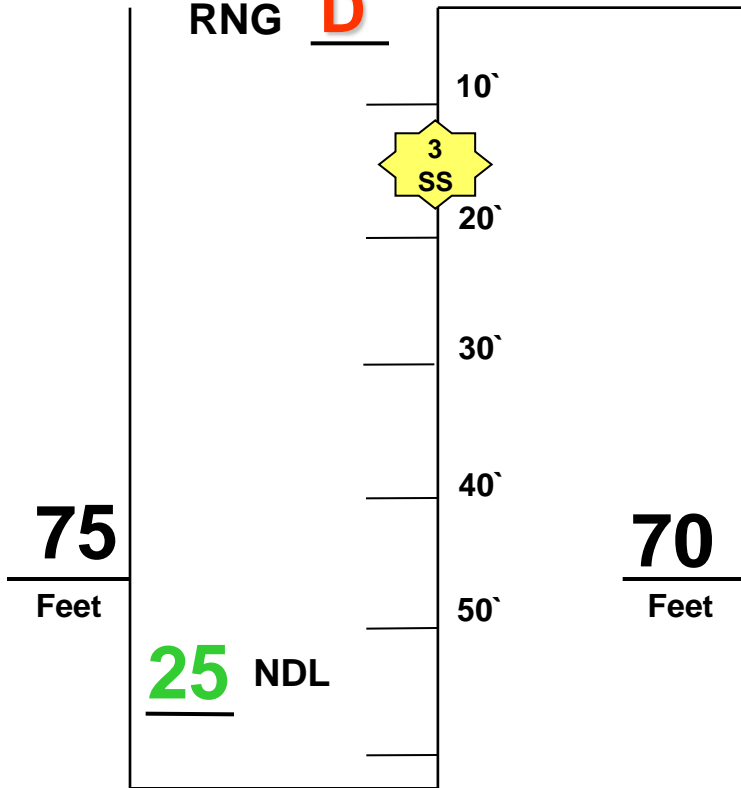

20 BT

What is the Minimum Surface Interval Between Dive #2 and #3

Surface Interval
2 Hr. 00 min.

SIG R3

RNG E

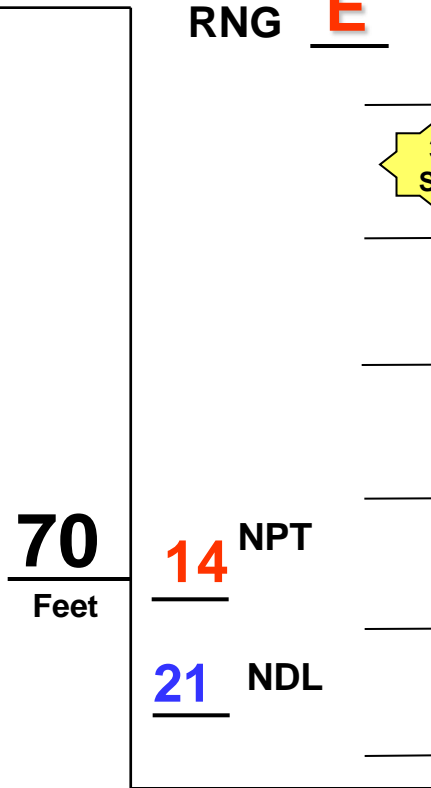

20 ABT

+ 14 NPT

34 TBT

Surface Interval
2 Hr. 00 min.

SIG R3

RNG E

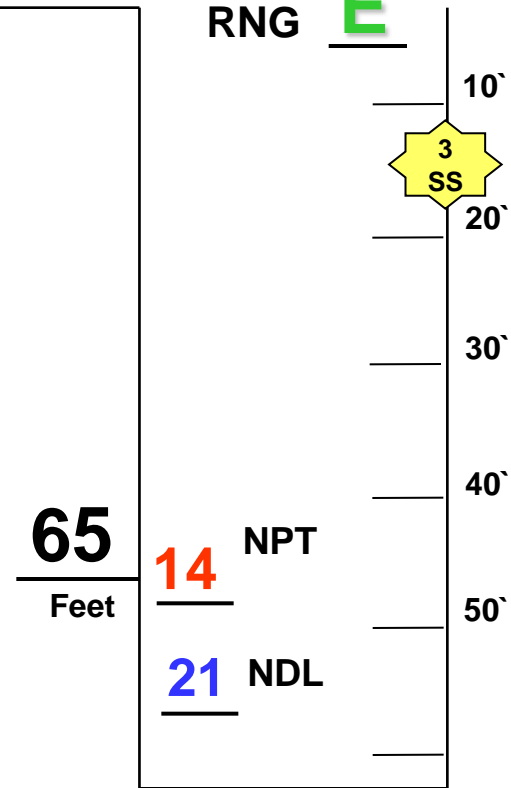

20 ABT

+ 14 NPT

34 TBT

Air Sport Dive Table Worksheet

Surface Interval
9 Hr. 00 min.

SIG R1

Surface Interval
____ Hr. ____ min.

SIG _____

RNG E

RNG _____

RNG _____

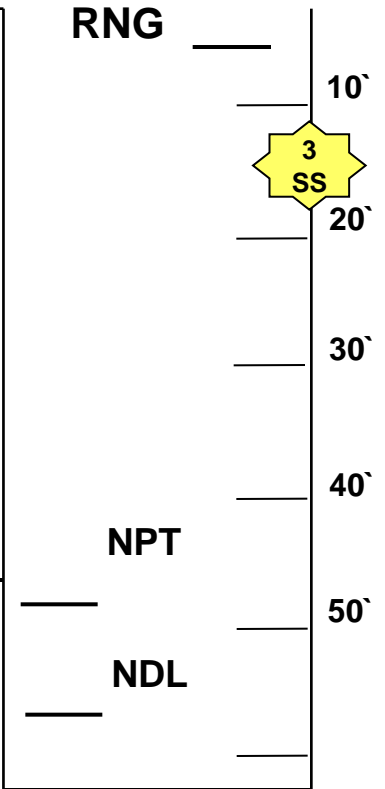
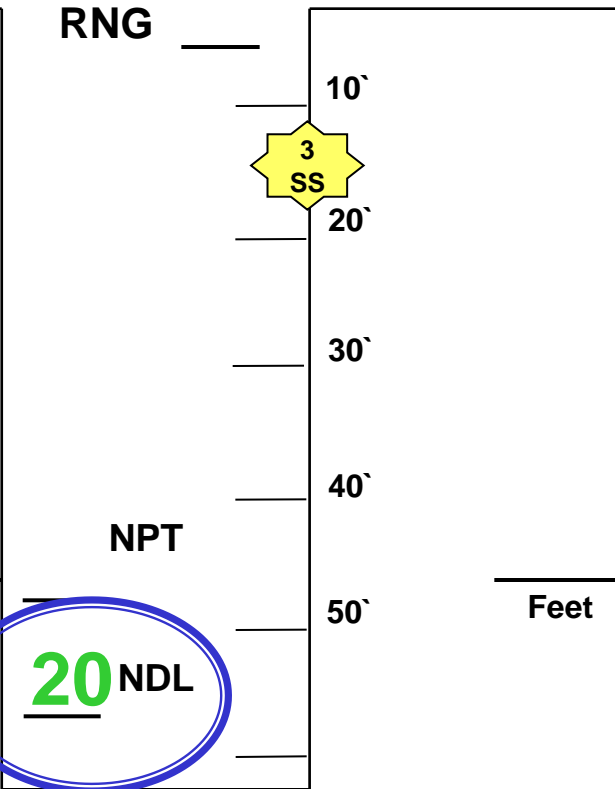
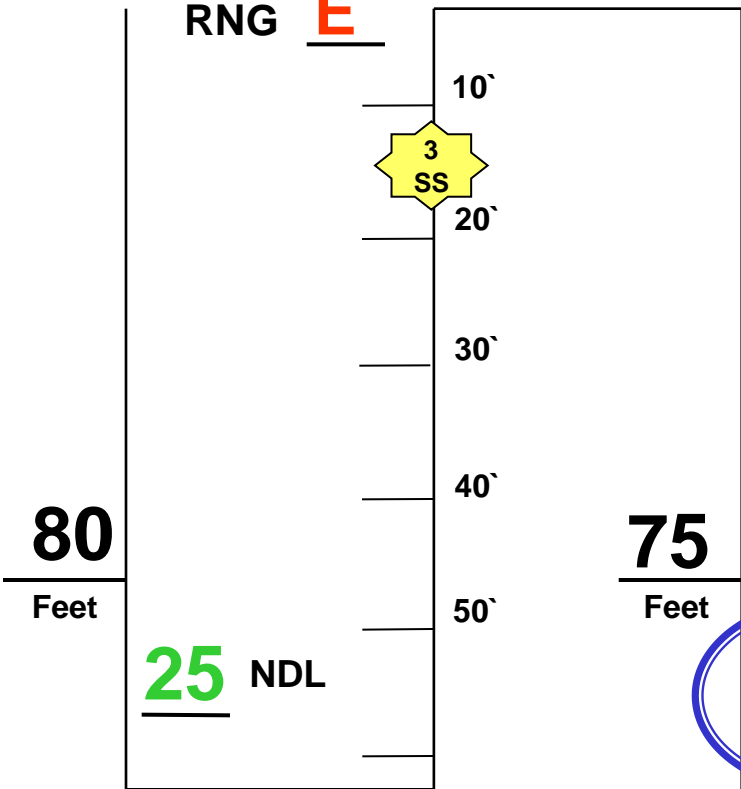

25 BT

20 ABT

____ ABT

What Is The NDL For
The Dive #2?

+ _____ NPT

+ _____ NPT

____ TBT

____ TBT



ALTITUDE DIVING

 If you must go to an altitude above 1000'/305m before reaching F/E/L (minimum) Surface Interval (ie: drive over a mountain), plan your dive using the Altitude Tables for the height you are traveling over

 **Depth + (Depth x Altitude/1000 x 4%)**

 **Example: 50 ft dive at 2000 ft altitude**
 $50 + (50 \times 2 \times 4\%) = 54$ ft dive

Flying After Diving....

-  For single **NO DECOMPRESSION** dives, must be at least “F/E/L” (Free) in Table B
-  All other dives minimum **24 hours** between your last dive and flying

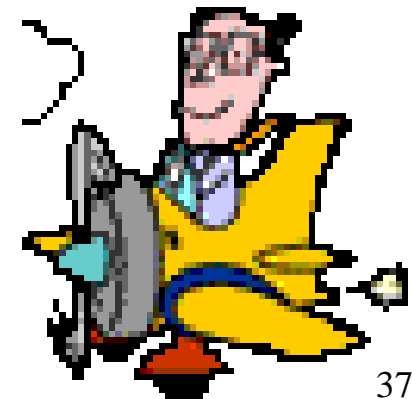

ACUC Dive Tables

Table A: Safety or Decompression Stops

ACUC RECREATIONAL DIVE TABLES / TABLES DE PLONGÉE RÉCRÉATIVE ACUC / TABLAS ACUC DE BUCEO RECREATIVO

See warning in instructions / Voyez l'avertissement dans les instructions / Ver aviso en las instrucciones



TABLE A: RESIDUAL NITROGEN GROUP (RNG) AND SAFETY OR DECOMPRESSION STOPS

GRUPE D'AZOTE RÉSIDUEL (GAR) ET PALIERS DE SÉCURITÉ OU OBLIGATOIRES

GRUPO DE NITROGENO RESIDUAL (GNR) Y PARADAS DE SEGURIDAD O DE DESCOMPRESION

DIVE LENGTH IN MINUTES – (SAFETY OR DECO STOP) / TEMPS DE PLONGÉE EN MINUTES - (PALIER DE SÉCURITÉ OU DE DÉCOMPRESION)
 TIEMPO DE INMERSION EN MINUTOS (PARADA DE SEGURIDAD O DE DESCOMPRESION)

D / P	30	60	90	120	150	180	240	300	360	420	480	600
6m/20'	30	60	90	120	150	180	240	300	360	420	480	600
9m/30'	30	45	60	90	100	120	150	180	190	210	240	270
12m/40'	22 (S)	30 (S)	40 (S)	60 (S)	70 (S)	80 (S)	90 (S)	120 (S)	130 (S)	150 (S)	160 (1)	170 (1)
15m/50'	18 (S)	25 (S)	30 (S)	40 (S)	50 (S)	60 (S)	75 (S)	85 (1)	95 (1)	105 (2)	115 (2)	124 (3)
18m/60'	14 (S)	20 (S)	25 (S)	30 (S)	40 (S)	50 (S)	60 (1)	70 (2)	80 (2)	85 (3)	92 (4)	
21m/70'	12 (S)	15 (S)	20 (S)	25 (S)	35 (S)	40 (1)	50 (2)	60 (5)	63 (5)	66 (6)		
24m/80'	10 (S)	13 (S)	15 (S)	20 (S)	25 (S)	29 (1)	35 (2)	48 (5)	52 (6)			
27m/90'	9 (S)	12 (S)	15 (S)	20 (S)	23 (1)	27 (2)	35 (5)	40 (6)	43 (6)			
30m/100'	7 (S)	10 (S)	12 (S)	15 (S)	18 (1)	21 (2)	25 (5)	29 (5)	36 (6)			
33m/110'	6 (S)	10 (S)	12 (S)	15 (1)	18 (2)	22 (5)	26 (6)	30 (6)				
36m/120'	6 (S)	8 (S)	10 (S)	12 (1)	15 (2)	19 (5)	25 (6)					
39m/130'	5 (S)	8 (S)	10 (1)	13 (2)		16 (5)	21 (6)					
42m/140'	5 (S)	7 (S)	9 (1)	11 (2)		14 (5)	18 (6)					
RNG GAR/GNR>	A	B	C	D	E	F	G	H	I	J	K	L
Deco Code:	(S)	(1)	(2)	(3)	(4)	(5)	(6)					
Minutes:	3	5	10	15	20	5	10	10	10			
D / P:	4.5m / 15'	3m / 10'	3m / 10'	3m / 10'	3m / 10'	3m / 10'	3m / 10'	6m 20'	3m 10'	6m 20'	3m 10'	

SESSION OBJECTIVES

Identify and utilize the ACUC Diving Tables to successfully complete the following:

- 1. Single non-repetitive dive**
- 2. Repetitive dive**
- 3. Multi-Level dive (discussion only)**
- 4. Altitude diving (rule of 4%)**
- 5. Discuss flying after diving**
- 6. Review Decompression schedules**

ACUC DIVE TABLES

Thank you for your attention

SAFE DIVING



**KELSEY SCUBA
CLUB**